

FEATURES

- HIGH POWER BANDWIDTH — 350kHz
- HIGH SLEW RATE — 20V/μs
- FAST SETTling TIME — 600ns
- LOW CROSSOVER DISTORTION — Class A/B
- LOW INTERNAL LOSSES — 1.2V at 2A
- HIGH OUTPUT CURRENT — ±5A PEAK
- LOW INPUT BIAS CURRENT — FET Input
- ISOLATED CASE — 300 VDC

APPLICATIONS

- MOTOR, VALVE AND ACTUATOR CONTROL
- MAGNETIC DEFLECTION CIRCUITS UP TO 5A
- POWER TRANSDUCERS UP TO 350 kHz
- AUDIO AMPLIFIERS UP TO 30W RMS

DESCRIPTION

The PA02 and PA02A are wideband, high output current operational amplifiers designed to drive resistive, inductive and capacitive loads. Their complementary “collector output” stage can swing close to the supply rails and is protected against inductive kickback. For optimum linearity, the output stage is biased for class A/B operation. The safe operating area (SOA) can be observed for all operating conditions by selection of user programmable, current limiting resistors (down to 10mA). Both amplifiers are internally compensated but are not recommended for use as unity gain followers. For continuous operation under load, mounting on a heatsink of proper rating is recommended.

These hybrid integrated circuits utilize thick film (cermet) resistors, ceramic capacitors and semiconductor chips to maximize reliability, minimize size and give top performance. Ultrasonically bonded aluminum wires provide reliable interconnections at all operating temperatures. The 8-pin TO-3 package is hermetically sealed and electrically isolated. Isolation washers are not recommended. The use of compressible thermal washers and/or improper mounting torque will void the product warranty. Please see “General Operating Considerations”.

EQUIVALENT SCHEMATIC

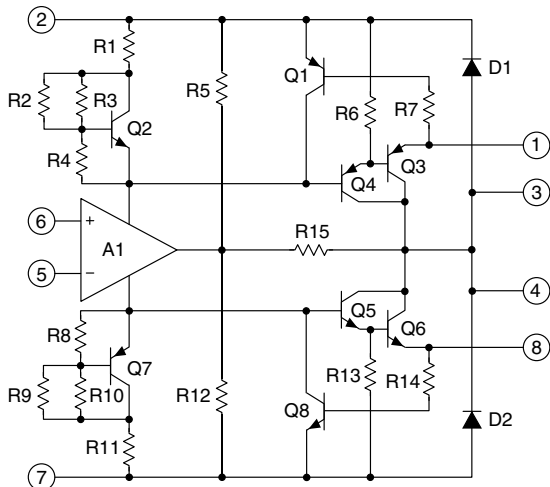

**8-PIN TO-3
PACKAGE STYLE CE**

TYPICAL APPLICATION

Vehicular Sound System Power Stage

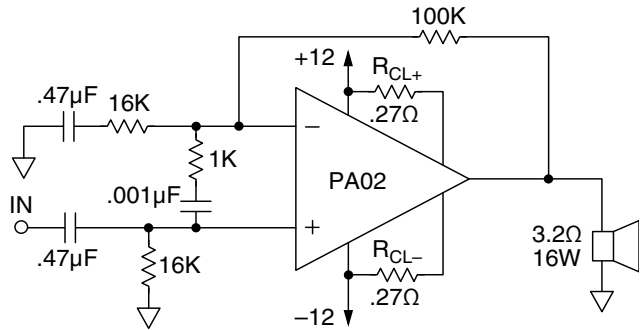

LOW INTERNAL LOSS MAXIMIZES EFFICIENCY

When system voltages are low and power is at a premium, the PA02 is a natural choice. The circuit above utilizes not only the feature of low internal loss of the PA02, but also its very low distortion level to implement a crystal clear audio amplifier suitable even for airborne applications. This circuit uses AC coupling of both the input signal and the gain circuit to render DC voltage across the speaker insignificant. The resistor and capacitor across the inputs form a stability enhancement network. The 0.27 ohm current limit resistors provide protection in the event of an output short circuit.

EXTERNAL CONNECTIONS

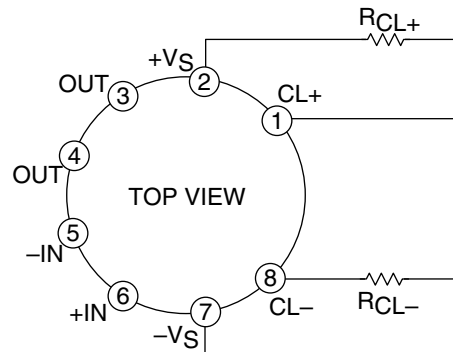

PA02 • PA02A

ABSOLUTE MAXIMUM RATINGS
SPECIFICATIONS



Product Innovation From



ABSOLUTE MAXIMUM RATINGS

SUPPLY VOLTAGE, $+V_S$ to $-V_S$	38V
OUTPUT CURRENT, within SOA	5A
POWER DISSIPATION, internal ¹	48W
INPUT VOLTAGE, differential	$\pm 30V$
INPUT VOLTAGE, common mode	$-V_S + 2V$ to $+V_S - 2V$
TEMPERATURE, pin solder - 10s	300°C
TEMPERATURE, junction ¹	150°C
TEMPERATURE RANGE, storage	-65 to +150°C
OPERATING TEMPERATURE RANGE, case	-55 to +125°C

SPECIFICATIONS

PARAMETER	TEST CONDITIONS ^{2,6}	PA02			PA02A			UNITS
		MIN	TYP	MAX	MIN	TYP	MAX	
INPUT								
OFFSET VOLTAGE, initial	$T_C = 25^\circ C$		± 5	± 10		± 1	± 3	mV
OFFSET VOLTAGE, vs. temperature	Full temperature range		± 10	± 50		*	± 25	$\mu V/^\circ C$
OFFSET VOLTAGE, vs. supply	$T_C = 25^\circ C$		± 10			*		$\mu V/V$
OFFSET VOLTAGE, vs. power	$T_C = 25^\circ C$		± 6			*		$\mu V/W$
BIAS CURRENT, initial	$T_C = 25^\circ C$		50	200		25	100	pA
BIAS CURRENT, vs. temperature	$T_C = 85^\circ C$			200		*	*	$pA/^\circ C$
BIAS CURRENT, vs. supply	$T_C = 25^\circ C$.01			*		pA/V
OFFSET CURRENT, initial	$T_C = 25^\circ C$		25	100		15	50	pA
OFFSET CURRENT, vs. temperature	$T_C = 85^\circ C$			100		*	*	$pA/^\circ C$
INPUT IMPEDANCE, DC	$T_C = 25^\circ C$		1000			*		$G\Omega$
INPUT CAPACITANCE	$T_C = 25^\circ C$		3			*		pF
COMMON MODE VOLT. RANGE ⁵ , Pos.	Full temperature range	$+V_S - 6$	$+V_S - 3$		*	*		V
COMMON MODE VOLT. RANGE ⁵ , Neg.	Full temperature range	$-V_S + 6$	$-V_S + 5$		*	*		V
COMMON MODE REJECTION, DC	Full temperature range	70	100		*	*		dB
GAIN								
OPEN LOOP GAIN at 10Hz	$T_C = 25^\circ C$, 1k Ω load		103			*		dB
OPEN LOOP GAIN at 10Hz	Full temp. range, 10k Ω load	86	100		*	*		dB
GAIN BANDWIDTH PRODUCT at 1MHz	$T_C = 25^\circ C$, 10 Ω load		4.5			*		MHz
POWER BANDWIDTH	$T_C = 25^\circ C$, 10 Ω load		350			*		kHz
PHASE MARGIN	Full temp. range, 10 Ω load		30			*		°
OUTPUT								
VOLTAGE SWING ³	$T_C = 25^\circ C$, $I_O = 5A$, $R_{CL} = .08\Omega$	$\pm V_S - 4$	$\pm V_S - 3$		*	*		V
VOLTAGE SWING ³	Full temp. range, $I_O = 2A$	$\pm V_S - 2$	$\pm V_S - 1.2$		*	*		V
CURRENT, peak	$T_C = 25^\circ C$	5			*	*		A
SETTLING TIME to .1%	$T_C = 25^\circ C$, 2V step		.6			*		μs
SLEW RATE	$T_C = 25^\circ C$	13	20		*	*		V/ μs
CAPACITIVE LOAD	Full temp. range, $A_V > 10$		SOA			*		
HARMONIC DISTORTION	$P_O = .5W$, $F = 1kHz$, $R_L = 10\Omega$.004			*		%
SMALL SIGNAL rise/fall time	$R_L = 10\Omega$, $A_V = 1$		100			*		ns
SMALL SIGNAL overshoot	$R_L = 10\Omega$, $A_V = 1$		10			*		%
POWER SUPPLY								
VOLTAGE	Full temperature range	± 7	± 15	± 19	*	*	*	V
CURRENT, quiescent	$T_C = 25^\circ C$		27	40		*	*	mA
THERMAL								
RESISTANCE, AC junction to case ⁴	$F > 60Hz$		1.9	2.1		*	*	$^\circ C/W$
RESISTANCE, DC junction to case	$F < 60Hz$		2.4	2.6		*	*	$^\circ C/W$
RESISTANCE, junction to air			30			*		$^\circ C/W$
TEMPERATURE RANGE, case	Meets full range specifications	-25		+85	-55		+125	$^\circ C$

- NOTES: * The specification of PA02A is identical to the specification for PA02 in applicable column to the left.
1. Long term operation at the maximum junction temperature will result in reduced product life. Derate internal power dissipation to achieve high MTTF.
 2. The power supply voltage for all specifications is the TYP rating unless otherwise noted as a test condition.
 3. $+V_S$ and $-V_S$ denote the positive and negative supply rail respectively. Total V_S is measured from $+V_S$ to $-V_S$.
 4. Rating applies if the output current alternates between both output transistors at a rate faster than 60Hz.
 5. Exceeding CMV range can cause the output to latch.
 6. Full temperature specifications are guaranteed but not 100% tested.
 7. The absolute maximum negative input voltage is equal to the negative power supply voltage plus 1V ($-V_S + 1V$).

CAUTION

The internal substrate contains beryllia (BeO). Do not break the seal. If accidentally broken, do not crush, machine, or subject to temperatures in excess of 850°C to avoid generating toxic fumes.

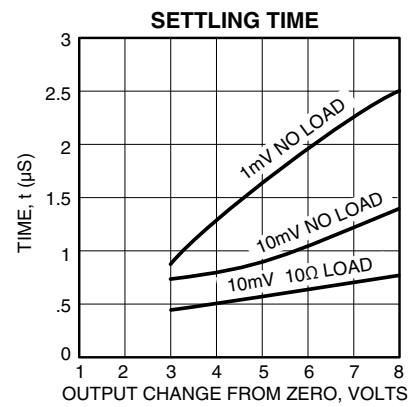
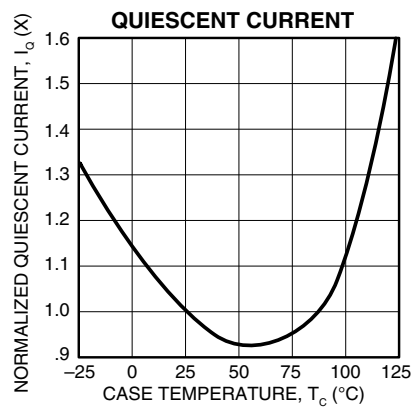
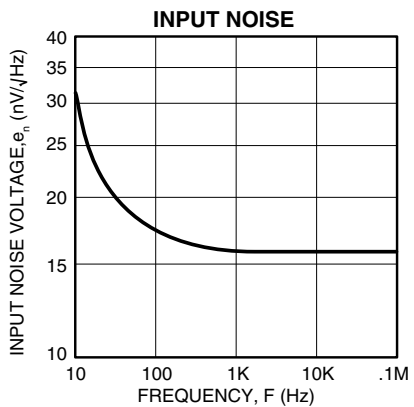
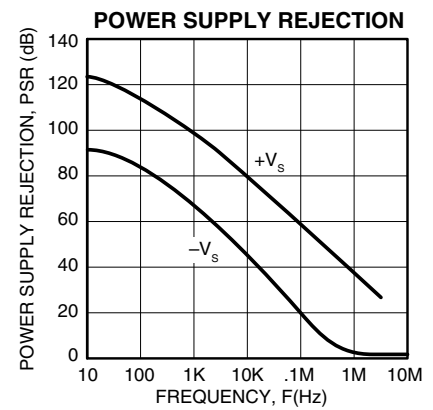
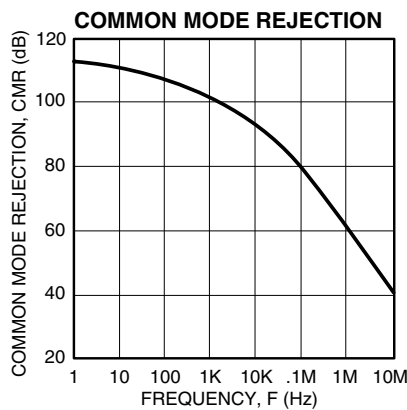
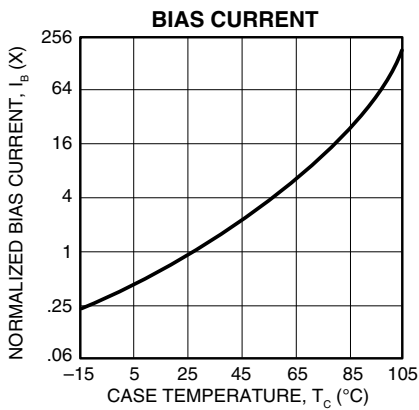
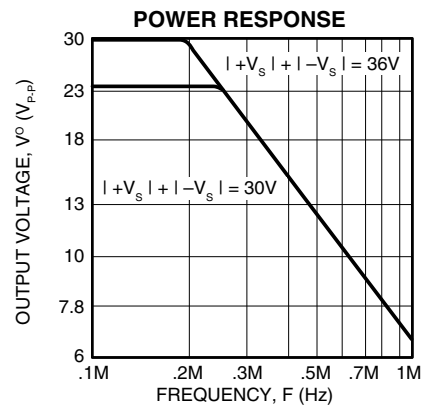
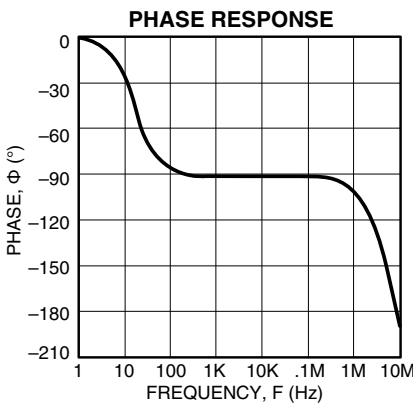
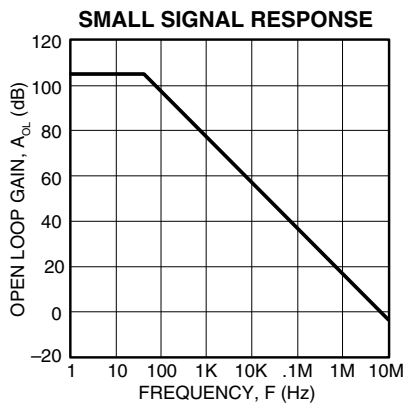
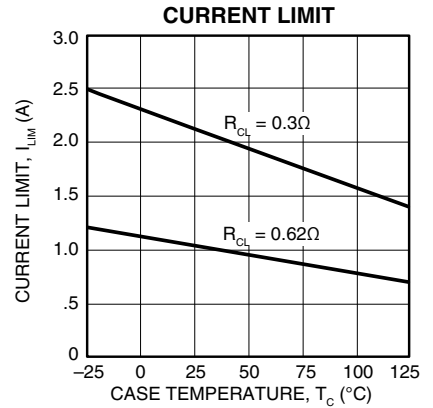
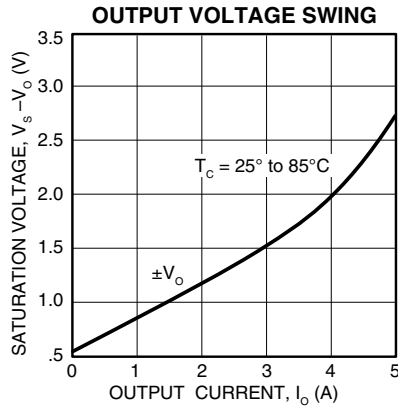
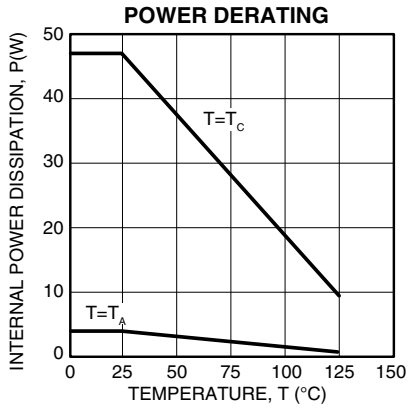

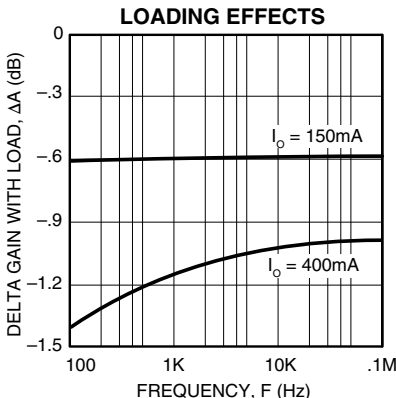
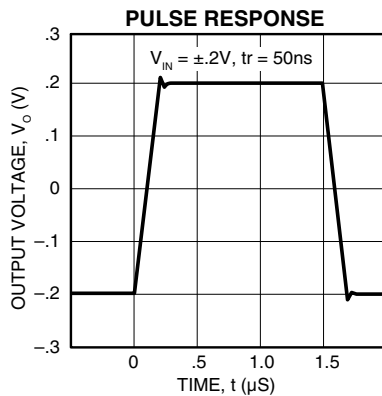
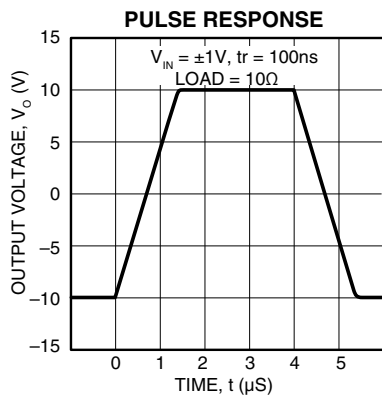
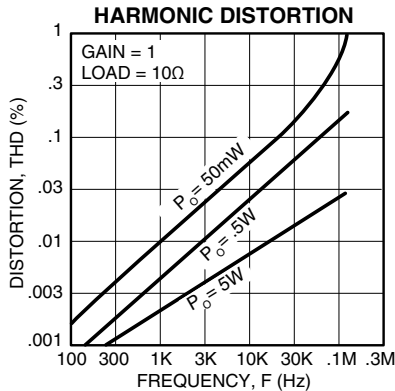

GENERAL

Please read Application Note 1 "General Operating Considerations" which covers stability, supplies, heat sinking, mounting, current limit, SOA interpretation, and specification interpretation. Visit www.apexmicrotech.com for design tools that help automate tasks such as calculations for stability, internal power dissipation, current limit; heat sink selection; Apex's complete Application Notes library; Technical Seminar Workbook; and Evaluation Kits.

SAFE OPERATING AREA

The SOA curves combine the effect of all limits for this Power Op Amp. For a given application, the direction and magnitude of the output current should be calculated or measured and checked against the SOA curves. This is simple for resistive loads but more complex for reactive and EMF generating loads. The following guidelines may save extensive analytical efforts:

- Under transient conditions, capacitive and dynamic* loads up to the following maximums are safe:

CAPACITIVE LOAD

$\pm V_S$	$I_{LIM} = 2A$	$I_{LIM} = 5A$
18V	2mF	0.7mF
15V	10mF	2.2mF
10V	25mF	10mF

INDUCTIVE LOAD

$I_{LIM} = 2A$	$I_{LIM} = 5A$
.2H	10mH
.7H	25mH
5H	50mH

* If the inductive load is driven near steady state conditions, allowing the output voltage to drop more than 8V below the supply rail with $I_{LIM} = 5A$, or 17V below the supply rail with $I_{LIM} = 2A$ while the amplifier is current limiting, the inductor should be capacitively coupled or the current limit must be lowered to meet SOA criteria.

- The amplifier can handle any EMF generating or reactive load and short circuits to the supply rails or shorts to common if the current limits are set as follows at $T_c = 85^\circ C$.

$\pm V_S$	SHORT TO $\pm V_S$ C, L OR EMF LOAD	SHORT TO COMMON
18V	.5A	1.7A
15V	.7A	2.8A
10V	1.6A	4.2A

These simplified limits may be exceeded with further analysis using the operating conditions for a specific application.

CURRENT LIMIT

Proper operation requires the use of two current limit resistors, connected as shown in the external connection diagram. The minimum value for R_{CL} is 0.12 ohm, however for optimum reliability it should be set as high as possible. Refer to the "General Operating Considerations" section of the handbook for current limit adjust details.

DEVICE MOUNTING

The case (mounting flange) is electrically isolated and should be mounted directly to a heatsink with thermal compound. Screws with Belleville spring washers are recommended to maintain positive clamping pressure on heatsink mounting surfaces. Long periods of thermal cycling can loosen mounting screws and increase thermal resistance.

Since the case is electrically isolated (floating) with respect to the internal circuits it is recommended to connect it to common or other convenient AC ground potential.

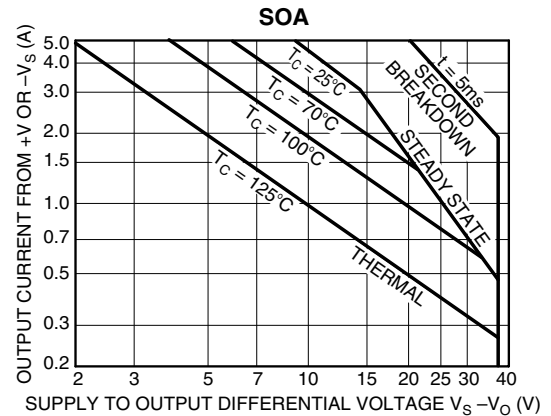



Product Innovation From



CIRRUS LOGIC®

PA02 • PA02A

Copyright © 2007 Cirrus Logic, Inc.
All rights reserved
Printed in the USA

Cirrus Logic, Inc. and its subsidiaries ("Cirrus") believe that the information contained in this document is accurate and reliable. However, the information is subject to change without notice and is provided 'as is' without warranty of any kind (express or implied). Customers are advised to obtain the latest version of relevant information to verify, before placing orders, that information being relied upon is current and complete. All products are sold subject to the terms and conditions of sales supplied at the time of order acknowledgement, including those pertaining to warranty, indemnification, and limitation of liability. No responsibility is assumed by Cirrus for the use of this information, or for infringement of patents or other rights of third parties. This document is the property of Cirrus and, by furnishing this information, Cirrus grants no license, express or implied, under any patents, mask work rights, copyrights, trademarks, trade secrets, or other intellectual property rights. No part of this publication may be copied, reproduced, stored in a retrieval system, or transmitted, in any form or by any means (electronic, mechanical, photographic, or otherwise) unless distributed in its entirety with all copyright notices attached. No part of this publication may be used as a basis for manufacture or sale of any items without the prior

written consent of Cirrus. Certain applications using semiconductor products may involve potential risks of death, personal injury, or severe property or environmental damage ("critical applications"). Cirrus products are not designed, authorized, or warranted to be suitable for use in products surgically implanted into the body, automotive safety or security devices, life-support products or other critical applications, inclusion of Cirrus products in such applications is understood to be fully at the customer's risk and Cirrus disclaims and makes no warranty of merchantability and fitness for particular purpose, with regard to any Cirrus product that is used in such a manner. If the customer uses or permits the use of Cirrus products in critical products in critical applications, customer agrees, by such use, to fully indemnify Cirrus, its officers, directors, employees, distributors and other agents from any and all liability, including attorneys' fees and costs that may result from or arise in connection with these uses.

Cirrus Logic, Cirrus, the Cirrus Logic logo designs, Apex, and Apex Precision Power are trademarks of Cirrus Logic, Inc. All other brand and product names in this document may be trademarks or service marks of their respective owners.

CIRRUS LOGIC, INC. • 5980 N SHANNON ROAD, TUCSON, AZ 85741 USA • TELEPHONE (520) 690-8600
APPLICATIONS SUPPORT (800) 546-2739 • FAX (520) 888-3329 • EMAIL support@cirrus.com
ORDERS (520) 690-8601 • FAX (520) 690-7749 • EMAIL teamsales@cirrus.com